



PremNet[®] 5000 Chassis

Broadband Access System

- Cost-effective fiber optic backbone for your building, campus or metropolitan-area network
- Single-ring, dual main ring or multi-ring network capability
- 45 to 310 Mbps bandwidth for multiple data, voice, and video traffic all on the same network
- "Virtual networks" across long distances
- Unparalleled network fault tolerance for mission-critical applications

PremNet[®] 5000 Chassis

Broadband Access System

As an infrastructure of information highways develops across the country, managers of local, metropolitan and wide-area networks are converging their systems into integrated, managed networks that transparently carry large volumes of data, voice, and video traffic safely and efficiently. Milgo Solutions is at the forefront, streamlining and consolidating this information traffic.

The PremNet[®] high-speed broadband access system utilizes reliable, private fiber, SONET/SDH OC-3c/STM-1, ATM OC-3c/STM-1, or T3 circuits for high-speed backbone transport of LANs, data, voice, and video traffic between PremNet nodes. It acts as a sophisticated toolkit for constructing flexible, reliable, and easily managed backbone transport systems. These rings of information seamlessly interconnect and manage thousands of sensitive applications on a wide variety of interfaces throughout the world.

Designing networks with the PremNet 5000 eight-slot interface module chassis delivers the optimum solution – providing balance between cost, resilience, and functionality.

PremNet Broadband System Access Features

- Unilink 100 Mbps rings connected to each other or to SONET/SDH OC-3c/STM-1 155 Mbps rings for increased bandwidth and performance
- Multimedia data transmission all on the same backbone
- Choice of over 15 interface modules to customize your data, voice, and video transmission types to suit your price and performance needs
- Matrix-switched backplane eliminates configuration constraints, allowing any module to reside in any slot

- Single ring, dual counter-rotating ring or multi-ring network configurations
- The PremNet multi-ring feature allows up to 241 PremNet nodes in a single fiber backbone network
- Provides network-management support
- LEDs that provide node-operating status at a glance
- Software selectable, user-controlled bandwidth allocation in 5 Mbps increments
- Unparalleled network fault tolerance
- Plug-in access for interface modules
- Rack (19 or 23 inch) or tabletop mounting
- Four fans that cool the power supply and link modules

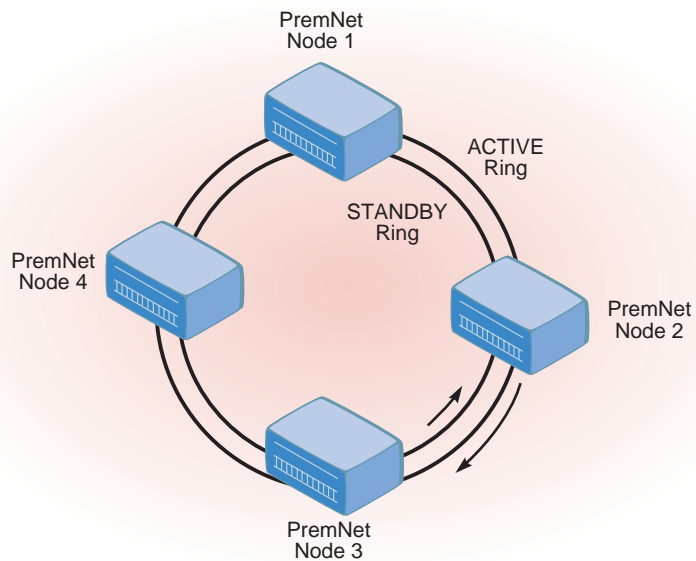

PremNet Supports Counter-Rotating Rings for Redundancy

Protocol-Transparent: Native Speeds

To facilitate easy network design and implementation, the PremNet nodes operate exclusively at the ISO physical level, making them completely transparent to all higher-level protocols. As a result, devices on the backbone can appear to be on the same logical network. This greatly extends the normal distances between network devices.

Because you can run multiple data types over the same PremNet backbone, you don't have to create separate networks to support each application type. This greatly consolidates and reduces cabling, saves room in wiring closets, and reduces hardware and maintenance costs. It also makes your network easier to manage, modify and expand. Since PremNet does not impose any special topology or connectivity restrictions, your LAN services can be bridged or routed easily via external equipment.

System-Wide Redundancy

Because of the critical nature of the information being transported across PremNet networks, the PremNet system is designed with full redundancy features that allow it to continue operating in the event of a power, link or node failure.

At the node level, the PremNet backplane is fully redundant, ensuring continued operation in the event that the primary backplane is unavailable. PremNet is the only product in its class to support this feature. PremNet also provides options for redundant power supplies, battery backup, operating logic and fiber links.

At the network level, backbone integrity cannot be compromised. The PremNet counter-rotating ring architecture plus protection switching functionality maintains the backbone's integrity in the event of a node failure or a fiber fault between two nodes. Ring recovery is extremely rapid, typically less than 3/4 second.

To ensure "protection switching," each PremNet node uses two link modules to support counter-rotating rings. In this configuration, the active and standby rings run in opposite directions, automatically healing the ring if it is broken. Connectivity is maintained even during loss of a node or loss of both fiber connections between any two nodes.

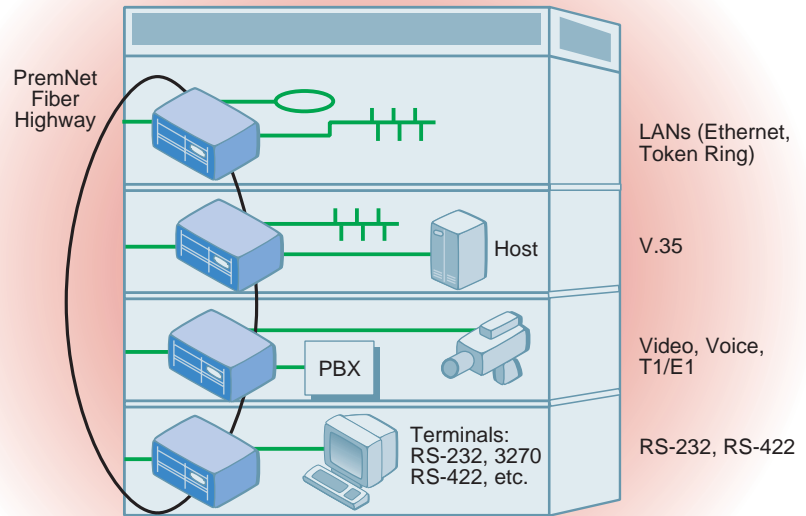

Information Distribution Within a Building

Bandwidth Management

Each PremNet chassis acts as a multi-interface distribution point. Information is distributed around the PremNet backbone network through a virtual circuit to any location on the ring. Virtual circuits are defined by the 3 x 3 matrix switch module, which allows bandwidth to be allocated based on the user's requirement via network management control.

The PremNet matrix switch, virtual circuit architecture allows dynamic software control of data paths, even when a new module or node is added to support more users or new applications. You can change the PremNet virtual circuits at any time using simple software commands. You also can redirect data through the network by adding, redefining, or deleting virtual circuits.

Integral matrix-switch technology also eliminates hardware slot dependence. Any module can be placed in any slot in any node.

Dedicated Bandwidth

Time-division multiplexing (TDM) is used to dedicate the bandwidth required for each application on a virtual circuit. This allows the PremNet backbone to provide a secure, transparent data pipe for each application. Dedicated bandwidth allows applications to run at native speed. For example, Ethernet or Token Ring LANs can be connected to remote facilities and yet still

operate at full native LAN speeds, as if the users on the LAN were in adjacent offices. This bandwidth is always available, ensuring consistent data delivery. This capability also fully supports time-sensitive applications, such as 4-wire voice and one-way and two-way video.

Choice of Network Management Interfaces

The PremNet network can be managed from a variety of network-management platforms: Your existing SNMP-compliant network-management system, the Milgo CMS[®] network management system, or the PremNet local on-board management.

SNMP – PremNet supports a Simple Network Management Protocol (SNMP) agent, which allows graphical management and control of the PremNet chassis and its modules (running under HP OpenView and Tivoli TME 10 NetView for AIX).

Milgo CMS Management System – The CMS Management System uses a graphical user interface to centrally manage and control the PremNet network.

Local Console – Text-based local access is available via an asynchronous terminal attached to any PremNet node on the ring. From a single terminal, a network manager can use simple menus to monitor and control port configurations, virtual circuits, and alarms. Remote dial access, using a standard modem, also is supported.

PremNet System Components

Each PremNet node supports a network management module, up to four redundant link modules, up to eight interface modules, two redundant matrix switch modules, and two redundant power supplies.

The common modules (power supply, link, switch and network management) are required for general system operation. These modules can be duplicated to achieve redundancy in the node. To operate properly, a PremNet chassis requires at least one of each of the following modules in a node:

- Power supply module
- One link module, with a maximum of four links per node (T3, SONET/SDH OC-3c/STM-1, ATM OC-3c/STM-1, Unilink LED/Laser)
- Switch module
- Network-management module

Power Supply Modules

There are two types of power supplies available:

AC – The AC power supply module is auto-ranging and automatically senses the voltage input and configures itself to accept voltages between 85 and 265 VAC.

-48 Vdc – The -48 Vdc power supply module accepts input from -42.5 to -60 Vdc. The source usually is a central-office battery or other non-interruptible DC source.

Any combination of power supplies can be used in a node. In redundant configurations, either power supply can be removed from the chassis without interrupting system operation.

Link Modules

The link module is the device located in each PremNet node on the network that enables communication over the ring. PremNet link interface modules include:

- The T3 link module
- The SONET/SDH OC-3c/STM-1 link module (available in a variety of transmission distances and connector types)
- Unilink interface modules (available in a variety of transmission distances and connector types)
- ATM OC-3c/STM-1 link module

Switch Modules

The 30/20 time-slot switch module provides the clock and timing required by the link for data transmission.

To achieve redundancy, install two switch modules in the chassis. Both modules have complete access to both sets of fiber links and all I/O modules.

The 30/20 switch supports up to 30 time slots on each of the three standard PremNet data streams (one from each of two pairs of link modules, and one from the node's interface modules). This switch module also can run in 20-time-slot mode.

The 30/20 switch is a nonblocking time/space switch: time slots within a frame can be reordered within a frame or moved from one data stream to another.

Enhanced Network-Management Modules

The enhanced network-management module (ENMM) provides complete network management for the PremNet broadband access system. It is SNMP compliant and includes features and capabilities for testing, monitoring, and error reporting.

Interface Modules

The PremNet family includes interface modules for the transparent transport of a wide variety of voice, video, and data traffic. These modules provide the interface for connecting end-user applications to the PremNet ring.

Available interface modules include:

- Ethernet
- Token Ring (4/16 Mbps)
- One-way and Two-way Video
- RS-232
- RS-422
- V.35
- T1/E1
- 4-Wire Voice

Your data, voice, and video network services can be available locally (for example, floor-to-floor within a building) or to users in multiple buildings connected via your PremNet fiber superhighway.

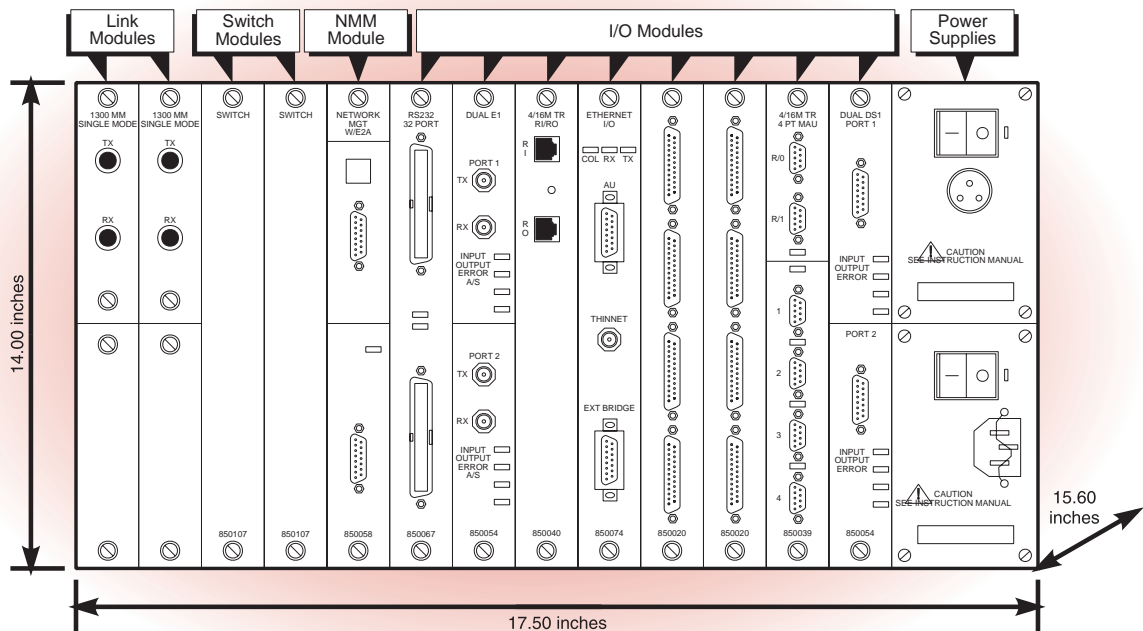

Ring Configurations

PremNet systems can be configured as single node or multinode. A single-node system is a stand-alone chassis with no link modules installed. Multinode systems typically are ring configurations. PremNet ring configurations include single-main ring, dual main ring, and multi-ring topologies.

Counter-Rotating Rings

The PremNet counter-rotating ring configuration gives you unparalleled network-fault tolerance. Fiber cuts and node failures are corrected through automatic ring recovery that maintains the ring's integrity.

Multi-Ring Networks

The PremNet 'backbones' unique multi-ring capability allows you to connect multiple PremNet fiber backbone rings to form a seamless, centrally managed multi-ring network. Multi-ring configurations combine the fault-tolerance capabilities of PremNet's counter-rotating ring with enhanced alarm reporting and fault recovery.

With a multi-ring configuration, you can connect up to 16 nodes per ring and up to 16 rings per network, allowing 241 nodes in a single backbone network. Currently, up to 76 nodes are tested in various multi-ring network configurations

Multi-Rings:

- Support spanning-tree configurations
- Use Enhanced Network-Management Module (ENMM) functions to support multi-rings
- Create virtual circuit connections between nodes on different rings

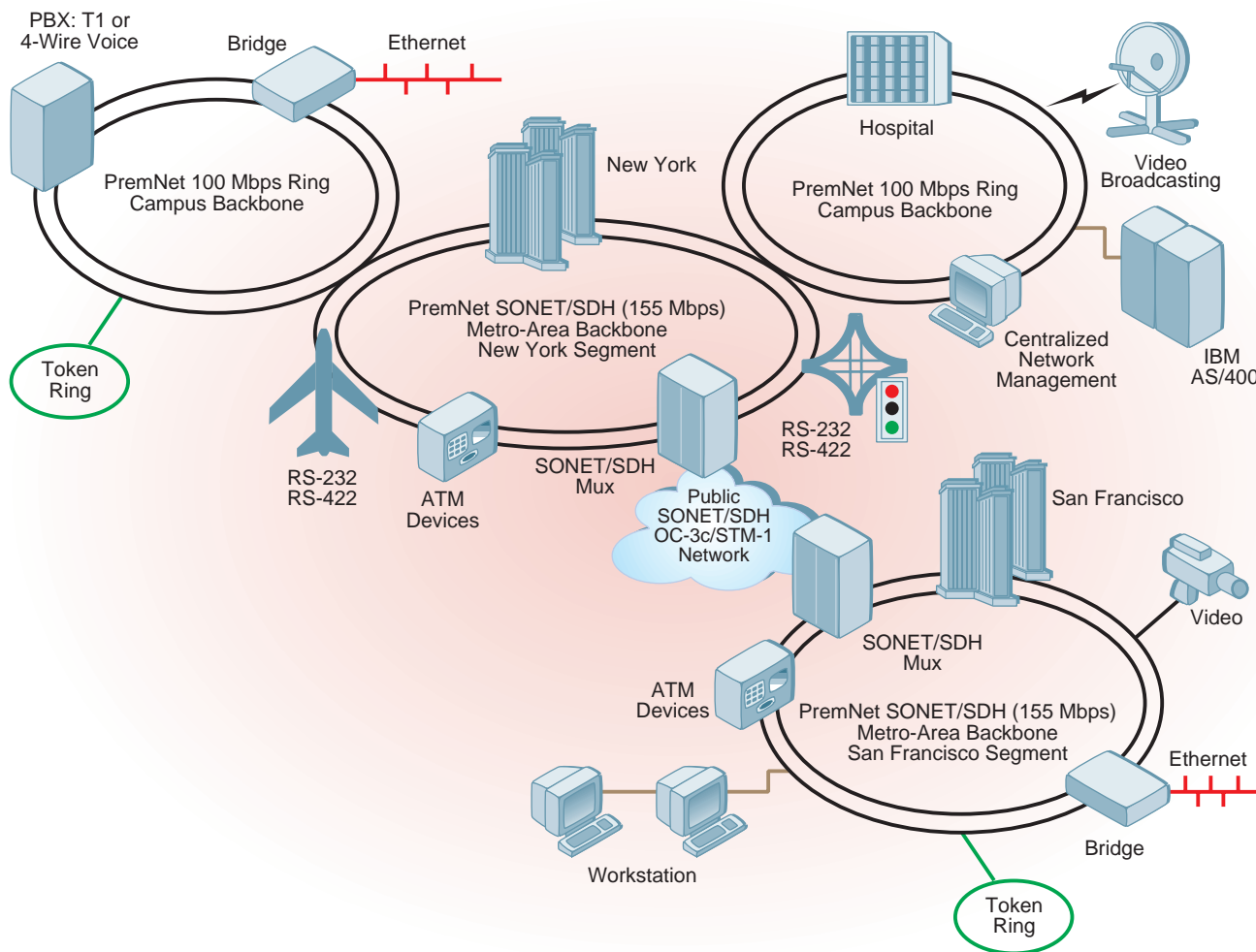

PremNet Data, Voice, ATM, and Video on a Multi-Ring SONET/SDH OC-3c/STM-1 Backbone

PremNet[®] 5000 Chassis

technical specifications

Part Numbers	PN950004	PremNet 5000 Chassis
	PN850107	20/30 Switch Module
	PN850079	AC Power Supply (115–230V)
	PN850080	DC Power Supply (-48V)
	PN800031	PremNet 5000 19 inch rack mount kit
	PN800046	PremNet 5000 23 inch rack mount kit
Bit Error Rate	10 ⁻⁹ or better	
System Bandwidth	4.704 - 141.121 Mbps	
Time Slot Routing	Virtual switched circuit	
Power	Domestic/International	85–265 VAC ±10%, 60 Hz
	Special	-48 Vdc
	Consumption	200 watts typical
Environmental	Operating temperature	32° to 122° F (0° to 50° C)
	Storage temperature	-40° to 158° F (-40° to 70° C)
	Humidity	95%, noncondensing
	Altitude	0–10,000 feet
Physical Specifications	Height	14.53 in. (36.90 cm)
	Width	17.50 in. (44.45 cm)
	Depth	15.60 in. (39.60 cm)
	Weight	40 lb. (18.16 kg)
	Mounting	Tabletop or rack mount
Network Management	The entire PremNet network can be managed via SNMP, the Milgo CMS Management System, or the PremNet integrated system.	
Network-Management Modules	Standard NMM and Enhanced NMM. For specific information about PremNet Network-Management Modules, a Network-Management Module data sheet is available upon request.	
Link Modules	SONET/SDH OC-3c/STM-1, ATM OC-3c/STM-1, T3, and 100 Mbps Unilink. For specific information about PremNet Link Modules, Link Interface Module data sheets are available upon request.	
Interface Modules	Ethernet, Token Ring (4/16 Mbps), V.35, T1/E1, RS-232, RS-422, 4-wire voice, one-way and two-way video. For specific information about a particular PremNet interface module, individual data sheets on each of the modules are available upon request.	

Our policy of continuous development may cause the information and specifications contained herein to change without notice.

PremNet and CMS are registered trademarks of Milgo Solutions, Inc. All other logos and product names are trademarks or registered trademarks of their respective companies.

©1999 Milgo Solutions, Inc. All rights reserved. Printed in U.S.A.

3C1369 5/99

MILGO
Solutions

Internet: <http://www.milgo.com>

Americas
1619 North Harrison Parkway
Sunrise, Florida 33323-2802, U.S.A.
Telephone: 1-800-333-4143
Telephone: 1-954-846-1601 (outside U.S.)
Fax: 1-954-846-4942

Europe / Middle East / Africa
Landata House, Station Road
Hook, Hampshire, RG27, 9JF, England
Telephone: 44-(0) 1256-763911
Fax: 44-(0) 1256-382059

Asia / Pacific
26 Ayer Rajah Crescent, #04-06
Ayer Rajah Industrial State
Singapore 139944
Telephone: 65-779-2200
Fax: 65-778-6400

